



ITT

Commercial Water

Red Jacket Water Products

GPC Gas Engine Self-Priming Portable
Contractor Pump Models 2GPC, 3GPC



2GPC



3GPC

FEATURES

- Lightweight, portable and compact design.
- Die cast aluminum casing, engine housing and volute.
- Durable cast iron impeller.
- Reliable Briggs and Stratton engines.
- Trouble-free mechanical seal, carbon/ceramic/BUNA-N.
- Fabricated carry handle base, rugged and convenient.
- Multi-position discharge connection.
- Injection molded suction strainer.
- Fittings to accommodate NPT connections.
- Available in 2 sizes: 2" connections, 3.5 HP; 3" connections, 5.5 HP Intek™ Pro.



Red Jacket Water Products is a brand of
ITT Residential and Commercial Water.

www.redjacketwaterproducts.com

Engineered for life



ITT

RED JACKET WATER PRODUCTS Commercial Water

PUMP SPECIFICATIONS

2GPC (2" Connections):

- Length: 20.50"
- Width: 15.00"
- Height: 15.75"
- Weight: 45 lbs.
- Solids: ½" Dia.

3GPC (3" Connections):

- Length: 20.75"
- Width: 15.50"
- Height: 17.25"
- Weight: 52 lbs.
- Solids: ½" Dia.

ENGINE SPECIFICATIONS

2GPC (2" Connections):

- Horsepower: 3.5 HP
- Displacement: 148 cc
- Fuel capacity: 2 qt.
- Oil capacity: 20 oz.
- Air cleaner: Paper
- Ignition: Electronic
- Governor: Pneumatic

3GPC (3" Connections):

- Horsepower: 5.5 HP
- Displacement: 190 cc
- Fuel capacity: 4 qt.
- Oil capacity: 20 oz.
- Air cleaner: Paper
- Ignition: Electronic
- Governor: Mechanical

2GPC PERFORMANCE – 3.5 HP

Flow (GPM)	0	25	50	75	100	125	145
TDH (Ft.)	105	96	80	60	40	20	0

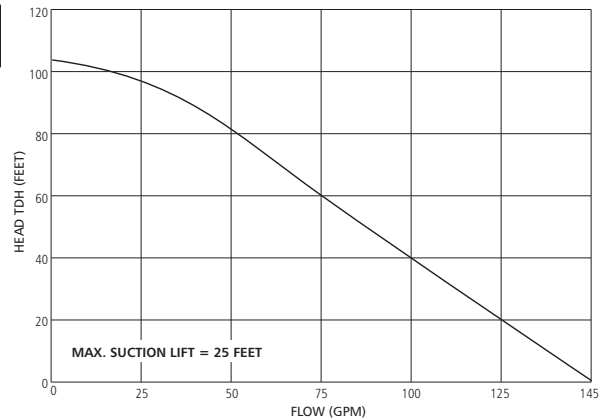

3GPC PERFORMANCE – 5.5 HP

Flow (GPM)	0	40	80	120	160	170
TDH (Ft.)	100	78	57	35	14	0

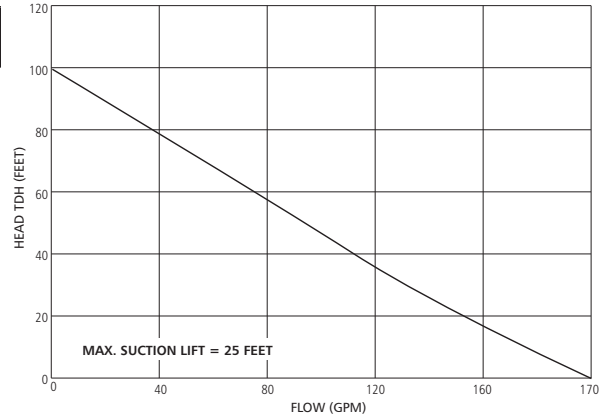



ITT

RED JACKET WATER PRODUCTS Commercial Water

DIMENSIONS AND WEIGHTS

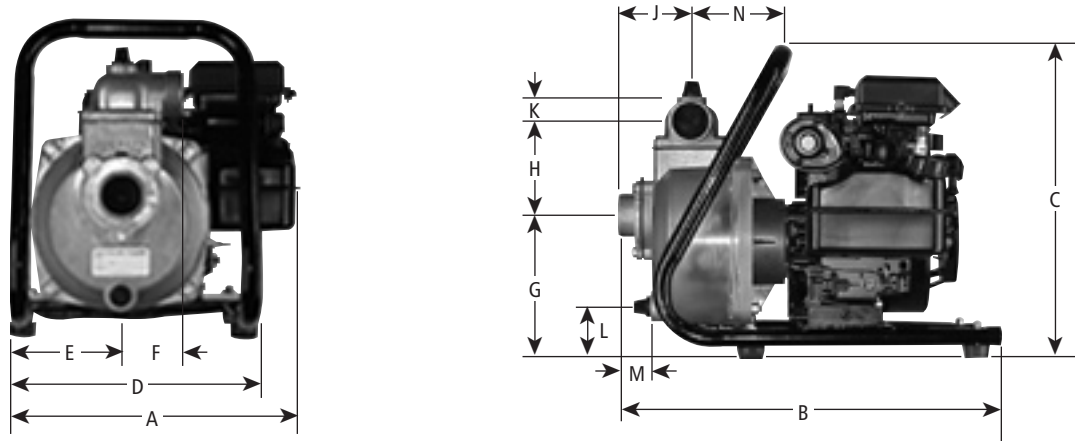

Model	Dimension (in inches)													Weight (lbs.)
	A	B	C	D	E	F	G	H	J	K	L	M	N	
2GPC	14 ³ / ₄	19 ¹ / ₂	18 ³ / ₄	12 ¹ / ₄	5 ¹ / ₄	2 ³ / ₄	7	5 ¹ / ₄	3 ³ / ₄	1 ¹ / ₂	2 ¹ / ₄	2	8	45
3GPC	16 ¹ / ₄	20 ³ / ₄	18 ³ / ₄	12 ¹ / ₄	4 ¹ / ₂	4 ¹ / ₂	7 ³ / ₄	7 ¹ / ₄	4 ³ / ₄	2	2 ¹ / ₂	2 ¹ / ₄	8 ¹ / ₄	52



ITT

Commercial Water

COMPONENTS LIST

Item No.	Part Description	Item No.	Part Description
1	Engine – 3 1/2 HP	9	Suction strainer
	Engine – 5 1/2 HP	10	Pump housing
2	Locknut – 3/8" – 16	11	Bolt – 3/8" – 16" x 1 1/2"
3	Engine adapter	12	O-ring, drain/filler plug
4	Aluminum washer – 5/16"	13	Drain/fill plug
5	Bolt – 5/16" – 24" x 3/4"	14	Flapper valve
6	Seal assembly	15	Suction flange BSP*
	Shaft sleeve		Suction flange NPT
	O-ring housing	16	Bolt – 5/16" – 18" x 7/8"
	O-ring volute		Discharge elbow BSP*
7	Impeller	17	Discharge elbow NPT
	Volute		Discharge gasket
	Imp. shim: 010, 020, 030	18	Discharge gasket
8*	Hose mounting gasket	19	Bolt – 5/16" – 18" x 1 1/2"
	Hose mounting nipple	20	Lock nut – 5/16" – 18
	Hose mounting nut	21	Cradle assembly
	Suction strainer		

*Supplied with 2GPC, built before September 2005.

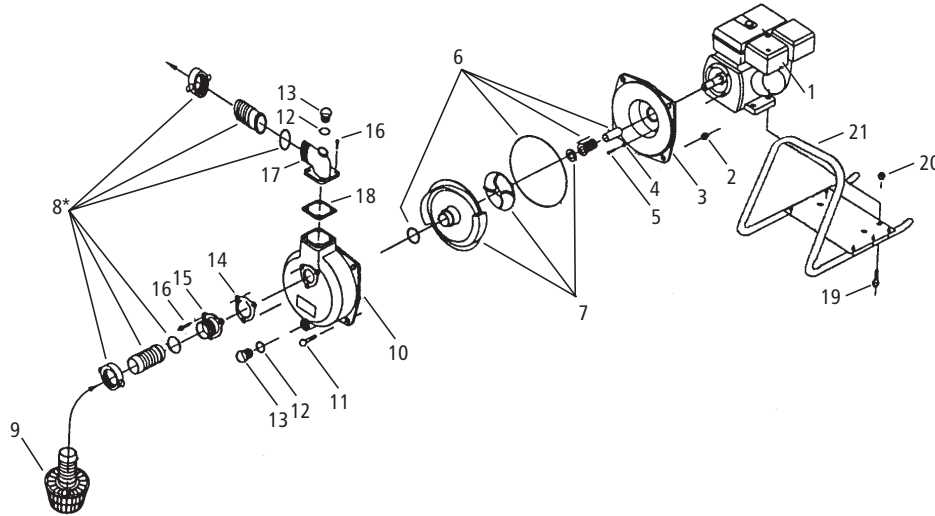

RED JACKET®
Water Products

Red Jacket Water Products is a licensed trademark. The ITT Engineered Blocks Symbol are registered trademarks and tradenames of ITT Corporation. Intek Pro is a trademark of Briggs and Stratton. SPECIFICATIONS ARE SUBJECT TO CHANGE WITHOUT NOTICE.

BRJGPC January, 2007
© 2007 ITT Corporation

Engineered for life